

U.P. COOPERATIVE SUGAR FACTORIES FEDERATION LTD.
9-A, RANA PRATAP MARG, LUCKNOW
Telephone: (0522) 2200183 Fax: (0522) 2627994
(0522)2628310 Email: upsugarfed@yahoo.co.in
Website: www.upsugarfed.org

**COMPETITIVE e-bidding FOR SUPPLY OF CHAIN AND THEIR SPARES
FOR VARIOUS COOP SUGAR FACTORIES IN UTTAR PRADESH FOR
THE SEASON 2024-25**

e-bid REFERENCE : **UPSUGARFED/CHAINSPARES/2024-25/P-10874**

LAST DATE AND TIME FOR SUBMISSION OF E-Bids : **28/02/2024 UPTO 06:55 PM**

DATE AND TIME OF OPENING OF ON LINE TECHNICAL e-Bids : **29/02/2024 AT 11:15 AM**

PLACE OF OPENING OF e-Bids : U.P. Cooperative Sugar Factories Federation Ltd.
9-A, Rana Pratap Marg, Lucknow

ADDRESS FOR COMMUNICATION : Managing Director
U.P. Cooperative Sugar Factories Federation Ltd.
9-A, Rana Pratap Marg, Lucknow

e-Bid E.M.D : **Rs. 75000/- (Seventy five Thousand Only)**

<u>BANK DETAILS – RTGS/NEFT</u>	
ACCOUNT HOLDER NAME	- U.P. COOPERATIVE SUGAR FACTORIES FEDERATION LTD. LUCKNOW
BANK ACCOUNT NO.	- 53012823858
BANK NAME	- STATE BANK OF INDIA
BRANCH	- VIDHAN SABHA MARG, LUCKNOW
IFSC	- SBIN0060284

This Document Contains -- 45 Pages

It will be the responsibility of the e-Bidders to check U.P. Government e-Procurement website <http://etender.up.nic.in> for any amendment through corrigendum in the e-tender document. In case of any amendment, e-Bidders will have to incorporate the amendments in their e-Bids accordingly.

e-tender Document Processing /Cost+18% GST : **Rs 2360.00**

INDEX

1	Short Term e-Tender Notice	03
2	Invitation of e-Bids	04-06
3	Section I- Instruction to Bidders	07-20
	(A) The e-Bid Document	07-08
	(B) Preparation of e-Bids	08-15
	(C) e-Bid Opening and Evaluation of e-Bid	15-19
	(D) Award of Contract	18-19
4	Section II- Conditions of e-Tender / Contract (cc)	20-23
5	Section III- Technical e-Bid	24
	III(A) e Bid form	25
	III(B) Schedule of Requirements	26
	III(C) Technical Specifications	27-33
	III (E) Performance Statement	34
	III (F) Capability Statement	35
	TO WHOM IT MAY CONCERN	36
	Check List	37-38
	Section IV- Financial e-Bid	39
	IV(A) e- Bid Form	40
	IV (B) Price Schedule/BOQ	41

UTTAR PRADESH COOPERATIVE SUGAR FACTORIES FEDERATION
LIMITED
9-A, RANA PRATAP MARG,LUCKNOW

P-10860/UPF/CP/2024-25

02/02/2024

E-TENDER NOTICE

On line e-tenders are invited from manufacturers/authorized distributors/Importers/Stockists/Channel partners/Authorised dealers (as per details given in tender documents) for supply of Roller Reshelling, Boiler Tubes, M.S.& G.I. pipe, Chain & Spares, Stainless Steel Tubes, Brass tubes, Roller shaft, A.M.C for turbine, Welding item, Bearings, Switchgear items, Pumps & spares, Domite tips , Color coated profile sheet, Aluminum sheet, Non-Asbestos sheet & Computer stationery to various Cooperative Sugar Factories of U.P.. The e-tender documents with detailed specifications make terms and conditions etc. can be downloaded from e- tender portal <http://etender.up.nic.in> & federation website www.upsugarfed.org time to time.

The Managing Director Federation reserves the right to cancel any or all bids/annul e-bidding process without assigning any reason & decision of Federation will be final & binding.

(RAMAKANT PANDEY)
MANAGING DIRECTOR

INVITATION FOR e-Bids

Online e-bids are invited for supply of **Chain and their spares** from different vendors to our cooperative sugar factories located in Uttar Pradesh.

1. Bidders are advised to study the tender Document carefully. Submission of e-Bid against this tender shall be deemed to have been done after careful study and examination of the procedures, terms and conditions of the tender Document with full understanding of its implications.
2. The e-Bid prepared in accordance with the procedures enumerated in ITB **Clause 15** of Section-I should be submitted through e-Procurement website <http://etender.up.nic.in>.
3. The tender document is available at e-Procurement website <http://etender.up.nic.in> or Federation's website www.upsugarfed.org from **03/02/2024 at 6:55 PM**. Interested bidders may view, download the e-Bid document, seek clarification and submit their e-Bid online up to the date and time mentioned in the table below:

(a)	Date of publication of e-tender notice & availability of Tender Document	Tender Notice has been published over e-Procurement website http://etender.up.nic.in and Federation's website www.upsugarfed.org and tender Document will be available from 03/02/2024 at 6:55 PM at e-Procurement web site http://etender.up.nic.in and Federation's website www.upsugarfed.org
(b)	Availability of tender document on website	03/02/2024 from 6:55 PM at e-Procurementweb site http://etender.up.nic.in and Federation's website www.upsugarfed.org
(c)	Clarification start date & time	03/02/2024 from 06:55 PM
(d)	Clarification end date & time	28/02/2024 upto 2:00 PM
(e)	Corrigendum can be uploaded	28/02/2024 upto 2:00 PM
(e)	e-Bid submission start date & time (Submission of e-tender fee, EMD and other supporting documents in PDF/XLS format)	03/02/2024 from 6:55 PM
(f)	e-Bid submission end date & Time	28/02/2024 upto 06.55 PM
(g)	Online technical e-Bid opening date & time	29/02/2024 at 11:15 AM
(h)	Online financial e-Bid opening date & time (Only of technically qualified bidders)	29/02/2024 at 03:00 PM

(i)	Venue of opening of technical & financial e-Bids	U.P. Cooperative Sugar Factories Federation Ltd. 9-A, Rana Pratap Marg, Lucknow.
(j)	Contact officer	Name: Mr. Vinod Kumar General Manager (P) Tel No: PBX (0522)-2615722, 2612849, Fax: (0522) 2627994, (0522)-2616884, Mob:- 78808810404
(k)	Cost of e-Bid document	Rs 2360.00 (Rupees Two Thousand Three Hundred Sixty Only) (Non-refundable)
(l)	e-Bid E.M.D	Rs 75000/- (Seventy five Thousand Only)
(m)	Earnest Money	Earnest Money & Tender Fee Deposited in Favour of U.P.Coop. Sugar Factories Federation Ltd through RTGS/NEFT/NET BANKING. The Details are as under. <u>Name of Beneficiary</u> :- U.P.Coop. Sugar Factories Federation Ltd <u>Bank Account No</u> :- 53012823858 <u>IFSC Code No</u> :- SBIN0060284 <u>Name of Bank Branch</u> :- Vidhan Sabha Marg Lucknow.

4. The bidders need to submit the proof/cost of e-Bid document/processing as stated in the above table through R.T.G.S./N.E.F.T. in favour of U.P. Cooperative Sugar Factories Federation Ltd (herein after referred as UPSUGAR FED/Purchaser) payable at Lucknow. The UTR number of transaction regarding N.E.F.T./R.T.G.S. along with the e-Bids should reach the office of UPSUGAR FED/Purchaser at Lucknow before opening of technical e-Bid.
5. All e-Bid must be accompanied by e-Bid Earnest Money Deposit (EMD) in the form of N.E.F.T./R.T.G.S., drawn in favour of U.P. Cooperative Sugar Factories Federation Ltd., Lucknow. The UTR number of transaction regarding N.E.F.T./R.T.G.S. along with the e-Bids should reach the office of UPSUGAR FED/Purchaser at Lucknow before opening of technical e-Bid. No Interest would be payable on e-Bid (Earnest Money) deposited with the Federation.
6. The Federation reserves the right to cancel any or all the e-Bids/annul the e-Bid process without assigning any reason thereof. The decision of Federation will be final and binding.
7. In the event of date specified for e-Bids opening being declared a holiday for Federation's office then the due date for opening of e-Bids shall be the following working day at the appointed time and place.
8. All the required documents including Price Schedule/BOQ should be uploaded by the e-Bidder electronically in the PDF/XLS format. The required electronic

documents for each document label of Technical (Fee details, Qualification details, e-Bid Form and Technical Specification details) schedules/packets can be clubbed together to make single different files for each label.

9. The companies/firms who are registered at e-Procurement portal for e-tendering with UP Electronics Corporation Ltd, 10 Ashok Marg, Lucknow-226002, would only be eligible for participating in this e-tender as well as in e-tendering system of U.P. Govt. departments. All companies/firms who have not registered themselves with UPLC Ltd ,Lucknow for e-tendering till date can get their registration done by depositing a filled in form issued by UPLC Ltd, Lucknow for participating in this e-tender and other e-tenders of U.P.Govt. Departments.

The companies/firms, who are not having digital signature, can also get their digital signature. The companies/firms may contact the officials on phone numbers (0522) 4130303 Extn 305 & 307, 09721451211, for their Registration/Digital Signature Certificate related queries. The registration fee may also be deposited through RTGS. The details of RTGS are as under:

M/s U.P. Electronics Corporation Ltd,
Punjab National Bank
Ashok Marg, Lucknow
A/C No. 7177002100000669
IFS code- PUNB0717700
Rs.6000/-

For E-Tendering Enquiry Please Contact Following Persons

- | | |
|--------------------------------------|-------------------------|
| 01.Sri Rritvik Saxena (Federation) - | 09415526023/07880888823 |
| 02.Vipul Srivastava (Federation) - | 7800001845 |

SECTION I : INSTRUCTIONS TO BIDDERS (ITB)

(A) THE BID DOCUMENT

1-Cost of e-Bid

- a) The bidder shall bear all costs associated with the preparation and submission of its e-Bid and U.P. Cooperative Sugar Factories Federation Ltd, Lucknow hereinafter referred to as “the Purchaser”, will in no case be responsible or liable for these costs, regardless of the conduct or outcome of the e-Bid process.
- b) This tender document is available on the web site <http://etender.up.nic.in> and www.upsugarfed.org to enable the bidders to view, download the e-Bid document and submit e-Bids online up to the last date and time mentioned in e-Tender notice/e-tender document against this e-Tender. The bidders shall have to pay e-Tender document fee of **Rs 2360.00 (Rupees Two Thousand Three Hundred Sixty RTGS/ NEFT/ NET BANKING** payable in favour of U.P. Cooperative Sugar Factories Federation Ltd, Lucknow. The E-tender document fee of Rs. 2360 will be Non-refundable.

2-Contents of e-Bid Document

- 2.1 The goods required to be supplied; e-Bid procedure and contract terms and conditions are prescribed in the e-Bid document. The e-Bid document includes:
Invitation for e-Bid

Section I	: Instruction to bidders (ITB);
Section II	: Conditions of E-tender/ Contract (CC);
Section III	: Technical e-Bid;
Section IV	: Financial e-Bid;

- 2.2 The bidder is expected to examine all instructions, forms, terms and specifications in the e-Bid document. Failure to furnish all information required as per the e-Bid document or submission of e-Bid not responsive to the e-Bid document in every respect will be at the bidder’s risk and may result in rejection of the said e-Bid.

3-Clarification of e-Bid Document

A prospective bidder requiring any clarification of the e-Bid document may raise his/her point of clarification through Bid Management Window after successfully login to the e-Procurement website <http://etender.up.nic.in>. The bidder may seek clarification by posting query in the relevant window after clicking "Seek Clarification" option in the view e-tender details window for e-tender which can be selected through my tender option of e-Bid submission menu. The clarification will be replied back by the Purchaser through the e-Procurement website which can be read by the bidder through the "Clarification" option under Bid Submission menu. The Purchaser may also respond to clarifications raised by the prospective bidders on Purchaser's e-mail address upsugarfed@yahoo.co.in.

4. Amendment of e-Bid Document

- 4.1 At any time prior to the deadline for submission of e-Bid, the Purchaser may, for any reason, whether at its own initiative or in response to a clarification requested by a prospective bidder, modify the e-Bid document by amendments. Such amendments shall be uploaded on the e-Procurement website [http:// etender.up.nic.in](http://etender.up.nic.in) and Purchaser's web site www.upsugarfed.org through corrigendum and shall form an integral part of e-Bid document. The relevant clauses of the e-Bid document shall be treated as amended accordingly.
- 4.2 It shall be the sole responsibility of the prospective bidders to check the web site <http://etender.up.nic.in> and www.upsugarfed.org from time to time for any amendment in the e-tender document. In case of failure to get the amendments, if any, the Purchaser shall not be responsible for it.
- 4.3 In order to allow prospective e-Bidders a reasonable time to take the amendment into account in preparing their e-Bids, the Purchaser, at his discretion, may extend the deadline for the submission of e-Bids. Such extensions shall be uploaded on the e-Procurement website <http://etender.up.nic.in> and Purchaser's web site www.upsugarfed.org.

(B) PREPARATION OF e-Bid

5 Language of e-Bid

- 5.1 The e-Bid prepared by the bidder, as well as all correspondence and documents relating to the e-Bid exchanged by the bidder and the Purchaser shall be written either in English or Hindi language. The correspondence and documents in Hindi must be accompanied by embedded/separate Hindi font files. Only English numerals shall be used in the e-Bid.

6 Documents Constituting the e-Bid

- 6.1 The e-Bid prepared by the bidder shall comprise the following components:
- (a) **Technical e-Bid** - Technical e-Bid will comprise of :
- (i) **Fee Details** includes copies of e-tender document processing/Cost and e-Bid Earnest Money Deposit furnished in accordance with ITB Clause 12 in PDF format.
- (ii) **Qualification Details** – includes copies of required documents as per ITB Clauses 10 and 11 in PDF format justifying that the bidder is qualified to perform the contract if his/her bid is accepted and that the bidder has financial, technical and production capability necessary to perform the contract and meets the criteria outlined in the Qualification Requirement and Technical Specification and fulfill all the conditions of the Contract and that the goods and ancillary services to be supplied by the bidder conform to the e-Bid document and Technical Specifications.

- (iii) **e-Bid Form** – includes copy of filled in e-Bid Form as per Section-III(A) of e-tender document in PDF format justifying that the bidder is complying with all the conditions of the Contract and Technical Specifications of the e-Bid Document as no deviation will be acceptable to the Purchaser.
- (iv) **Technical Specification Details** – includes copy of filled in Technical Specifications as per Section-III(C) of e-tender document in PDF format.
- (b) **Financial e-Bid** – Financial e-Bid will comprise of :
 - (i) **e-Bid Form** – includes copy of filled in e-Bid Form as per Section-IV (A) of e-tender document in PDF format.
 - (ii) **Price Schedule/BOQ** includes Price Schedule/BOQ in XLS format to be filled in after downloading from the e-Procurement website for this e-tender.

7-e-Bid Form

- 7.1 The bidder shall complete the e-Bid Form and the appropriate Price Schedule/BOQ furnished in the e-Bid document, including the goods to be supplied, their quantities and prices in the format given in the e-Bid document.

8 e-Bid Price

- 8.1 The bidder shall quote separately in the downloaded spread sheet file for the Basic Price **of Chain and their spares** to be supplied.
- 8.2 The price of goods (**Ex Works**)
 - (a) On components and raw material used in the manufacture or assembly of goods quoted **Ex Works**.
 - (b) Rate of **Chain and their spares** inclusive of packing forwarding loading charges, transit insurance and other relevant miscellaneous expenses, **excluding GST and transportation charges. The bidder has to submit relevant papers to the concerned mill to claim input tax credit.**
- 8.3 Prices quoted by the bidder shall be fixed during the bidder's performance of the Contract and not subject to variation on any account subject to ITB Clause 25.1. A e-Bid submitted with an adjustable price quotation unless asked for shall be treated as non-responsive and rejected.

9 e-Bid Currencies

Prices shall be quoted in Indian Rupees only.

10 Documents Establishing bidder's Qualification

Bid's Qualification

The bidder should have supplied at the material during last 05 years ending on the date of bidding and material should be in successful supply for at least 02 years on the date of bid opening.

DisQualification

Even if the applicant meets eligibility criteria and PQC he may be subject to disqualification if he or any or the constituent partner is found to have made the following :-

1-Misleading or false representations in the forms, statements, affidavits and attachments submitted in proof of the qualification requirement.

2-Bidders on account of currency of debarment by any Government agency.

11 Documents Establishing Goods' Conformity to e-Bid Documents

11.1 Pursuant to ITB Clause 6, the bidder shall furnish, as part of its e-Bid, documents establishing the conformity to the e-Bid documents of all goods and services which the bidder proposes to supply under the contract. The documentary evidence should be in the PDF file format.

12 e-Bid Earnest Money Deposit (EMD)

12.1 Pursuant to ITB Clause 6, the bidder shall furnish, as part of its e-Bid, an e-Bid EMD of **75000/- (Seventy five Thousand Only)** in form of RTGS/ NEFT/ NET BANKING, in favour of U.P. Cooperative Sugar Factories Federation Ltd., Lucknow. No Interest on EMD will be paid. **The UTR number of transaction regarding the RTGS/NEFT/NET BANKING must be submitted along with the e-bid.**

12.2 If the supplier /bidder is registered with M.S.M.E./Startup, may not submit such E.M.D at the time of technical bid opening. If the tender is final in favour of the supplier registered in the M.S.M.E./Startup, such bidder will have to submit Security Money as per tender document.

12.3 The e-Bid E.M.D is required to protect the Purchaser against the risk of bidder's conduct which would warrant the E.M.D's forfeiture, pursuant to ITB Clause 12.7.

12.4 The e-Bid E.M.D shall be in Indian Rupees and shall be in the following forms only:

A RTGS/ NEFT/ NET BANKING payable in favour of U.P. Cooperative Sugar Factories Federation Ltd. payable at Lucknow.

12.5 Any e-Bid not secured in accordance with ITB Clauses 12.1 and 12.3 above shall be treated as non-responsive and rejected by the Purchaser.

12.6 **Unsuccessful bidder's e-Bid E.M.D will be returned upon the written request through NEFT/R.T.G.S. as promptly as possible after the expiration of the period of e-Bid validity prescribed by the Purchaser, pursuant to ITB Clause 13.**

12.7 **The successful bidder's e-Bid E.M.D will be converted in security and in addition to EMD equal amount or decided by the purchase committee at the**

time of negotiation and before issue the rate contract will be deposited with Federation, pursuant to ITB Clause 28, and furnishing the performance security, pursuant to ITB Clause 29.

12.8 The e-Bid E.M.D may be forfeited:

- (a) if a bidder (i) withdraws its e-Bid during the period of e-Bid validity specified by the bidder on the e-Bid Form; or (ii) does not accept the correction of errors pursuant to ITB Clause 22.2; or (iii) modifies its e-Bid price during the period of e-Bid validity specified by the bidder on the e-Bid form or
- (b) In case of a successful bidder, if the bidder fails:
 - (i) to sign the Contract with the Purchaser in accordance with ITB Clause 28; or
 - (ii) To furnish performance security in accordance with ITB Clause 29.

13 Period of Validity of e-Bid

- 13.1 e-Bid shall remain valid up to 90 days and the Rate contract for the period up to which the crushing of season 2024-25 continues of the cooperative factories of federation or 30/06/2024 whichever is later after the date of e-Bid opening prescribed by the Purchaser, pursuant to ITB Clause 16. An e-Bid valid for a shorter period shall be rejected by the Purchaser as non-responsive.
- 13.2 In exceptional circumstances, the Purchaser may solicit the bidder's consent to an extension of the period of e-Bid validity. The request and the response thereto shall be made in writing. A bidder may refuse the request without forfeiting its e-Bid security. A bidder granting the request will not be required nor permitted to modify its e-Bid.

14 Format and Signing of e-Bid

- 14.1 The bidder shall prepare one electronic copy each of the Technical e-Bid and Financial e-Bid separately.
- 14.2 The e-Bid document shall be digitally signed, at the time of uploading, by the bidder or a person or persons duly authorized to bind the bidder to the Contract.

15. Submission of e-Bid

The Bid Submission module of e-Procurement website <http://etender.up.nic.in> enables the bidders to submit the e-Bid online in response to this e-tender published by the Purchaser. Bid Submission can be done only from the Bid Submission start date and time till the Bid Submission end date and time given in the e-tender. Bidders should start the Bid Submission process well in advance so that they can submit their e-Bid in time. The bidders should submit their e-Bid considering the server time displayed in the e-Procurement website. This server time is the time by which the e-Bid submission activity will be allowed till the permissible time on the last/end date of submission indicated in the e-tender schedule. Once the e-Bid submission date and time is over, the bidders cannot submit their e-Bid. For delay in submission of e-Bid due to any reasons, the bidders shall only be held responsible.

The bidders have to follow the following instructions for submission of their e-Bid:

- 15.1 For participating in e-Bid through the e-tendering system, it is necessary for the bidders to be the registered users of the e-Procurement website <http://etender.up.nic.in>. The bidders must obtain a User Login Id and Password by registering themselves with U.P. Electronics Corporation Limited, Lucknow if they have not done so previously for registration. Refer to details given in Invitation for e-Bid Clause 10.
- 15.2 In addition to the normal registration, the bidder has to register with his/her **Digital Signature Certificate (DSC)** in the e-tendering system and subsequently he/she will be allowed to carry out his/her e-Bid submission activities. Registering the Digital Signature Certificate (DSC) is one time activity. Before proceeding to register his/her DSC, the bidder should first log on to the e-tendering system using the User Login option on the home page with the Login Id and Password with which he/ she has registered as per clause 15.1 above.

For successful registration of DSC on e-Procurement website <http://etender.up.nic.in> the bidder must ensure that he/she should possess Class-2/ Class-3 DSC issued by any certifying authorities approved by Controller of Certifying Authorities, Government of India, as the e-Procurement website <http://etender.up.nic.in> is presently accepting DSCs issued by these authorities only. The bidder can obtain User Login Id and perform DSC registration exercise as described in clauses 15.1 and 15.2 above even before e-Bid submission date starts. The Purchaser shall not be held responsible if the bidder tries to submit his/her e-Bid at the last moment before end date of submission but could not submit due to DSC registration problem.

- 15.3 The bidder can search for active tenders through "Search Active tenders" link, select a tender in which he/she is interested in and then move it to 'My Tenders' folder using the options available in the e-Bid Submission menu. After selecting and viewing the tender, for which the bidder intends to e-Bid, from "My Tenders" folder, the bidder can place his/her e-Bid by clicking "Pay Offline" option available at the end of the view tender details form. Before this, the bidder should download the e-tender document and Price Schedule/Bill of Quantity (BOQ) and study them carefully. The bidder should keep all the documents ready as per the requirements of e-tender document in the PDF format except the Price Schedule/Bill of Quantity (BOQ) which should be in the XLS format (Excel sheet).
- 15.4 After clicking the 'Pay Online option, the bidder will be redirected to the Terms and Conditions page. The bidder should read the Terms & Conditions before proceeding to fill in the Tender Fee and EMD Online payment details. After entering and saving the Tender Fee and EMD details, the bidder should click "Encrypt & Upload" option given in the Online payment details form so that "Bid Document Preparation and Submission" window appears to upload the documents as per Technical (Fee details, Qualification details, e-Bid Form and Technical Specification details) and financial (e-Bid Form and Price Schedule/BOQ) schedules/packets given in the tender details.
- 15.5 Next the bidder should upload the Technical e-Bid documents for Fee details (e-tender fee and EMD), Qualification details as per "ITB Clause 10 or 21", e-Bid Form as per "Section-III(A)" and Technical Specification details as per "Section-III(C):Technical Specifications" and Financial e-Bid documents as per "Section-

IV(A):e-Bid Form" and "Section-IV(B):Price Schedule/BOQ" of e-tender document. Before uploading, the bidder has to select the relevant Digital Signature Certificate. He may be prompted to enter the Digital Signature Certificate password, if necessary. For uploading, the bidder should click "Browse" button against each document label in Technical and Financial schedules/packets and then upload the relevant PDF/XLS files already prepared and stored in the bidder's computer. The required documents for each document label of Technical (Fee details, Qualification details, e-Bid Form and Technical Specification details) and financial (e-Bid Form and Price Schedule/BOQ) schedules/packets can be clubbed together to make single different files for each label.

- 15.6 The bidder should click "Encrypt" next for successfully encrypting and uploading of required documents. During the above process, the e-Bid documents are digitally signed using the DSC of the bidder and then the documents are encrypted/locked electronically with the DSC's of the bid openers to ensure that the e-Bid documents are protected, stored and opened by concerned bid openers only.
- 15.7 After successful submission of e-Bid document, a page giving the summary of e-Bid submission will be displayed confirming end of e-Bid submission process. The bidder can take a printout of the bid summary using the "Print" option available in the window as an acknowledgement for future reference.
- 15.8 Purchaser reserves the right to cancel any or all e-Bids without assigning any reason.

16-Deadline for Submission of e-Bid

- 16.1 e-Bid (Technical and Financial) must be submitted by the bidders at e-Procurement website <http://etender.up.nic.in> not later than time 06.55 P.M and 28/02/2024 the date as mentioned on page 4 (as the server time displayed in the e-Procurement website).
- 16.2 The Purchaser may, at its discretion, extend this deadline for submission of e-Bid by amending the e-Bid document in accordance with ITB Clause 4, in which case all rights and obligations of the Purchaser and bidders previously subject to the deadline will thereafter be subject to the deadline as extended.

17 Late e-Bid

- 17.1 The server time indicated in the Bid Management window on the e-Procurement website <http://etender.up.nic.in> will be the time by which the e-Bid submission activity will be allowed till the permissible date and time scheduled in the e-tender. Once the e-Bid submission date and time is over, the bidder cannot submit his/her e-Bid. Bidder has to start the Bid Submission well in advance so that the submission process passes off smoothly. The bidder will only be held responsible if his/her e-Bid is not submitted in time due to any of his/her problems/faults, for whatsoever reason, during e-Bid submission process.

18 Withdrawal and Resubmission of e-Bid

- 18.1 At any point of time, a bidder can withdraw his/her e-Bid submitted online before the bid submission end date and time. For withdrawing, the bidder should first log in using his/ her Login Id and Password and subsequently by his/her Digital Signature Certificate on the e-Procurement website <http://etender.up.nic.in>. The bidder should then select "My Bids" option in the Bid Submission menu. The page listing all the bids submitted by the bidder will be displayed. Click "View" to see the details of the e-Bid to be withdrawn. After selecting the "Bid Withdrawal" option, the bidder has to click "Yes" to the message "Do you want to withdraw this bid?" displayed in the Bid Information window for the selected bid. The bidder also has to enter the bid Withdrawing reasons and upload the letter giving the reasons for withdrawing before clicking the "Submit" button. The bidder has to confirm again by pressing "Ok" button before finally withdrawing his/her selected e-Bid.
- 18.2 The bidder has to request the Purchaser with a letter, attaching the proof of RTGS/ NEFT/ NET BANKING and submission of e-Bid EMD in the office of Purchaser, to return back the e-Bid security/EMD as per RTGS/NEFT.
- 18.3 No e-Bid may be withdrawn in the interval between the deadline for submission of e-Bids and the expiration of period of e-Bid validity. Withdrawal of an e-Bid during this interval may result in the bidder's forfeiture of his/her e-Bid E.M.D, pursuant to ITB Clause 12.7.
- 18.4 The bidder can re-submit his/her e-Bid as and when required till the e-Bid submission end date and time. The e-Bid submitted earlier will be replaced by the new one. The payment made by the bidder earlier will be used for revised e-Bid and the new e-Bid submission summary generated after the successful submission of the revised e-Bid will be considered for evaluation purposes. For resubmission, the bidder should first log in using his/her Login Id and Password and subsequently by his/her Digital Signature Certificate on the e-Procurement website <http://etender.up.nic.in>. The bidder should then select "My Bids" option in the Bid Submission menu. The page listing all the bids submitted by the bidder will be displayed. Click "View" to see the details of the e-Bid to be resubmitted. After selecting the "Bid Resubmission" option, click "Encrypt & Upload" to upload the revised e-Bid documents by following the methodology provided in clauses 15.4 to 15.7.
- 18.5 The bidders can submit their revised e-Bids as many times as possible by uploading their e-Bid documents within the scheduled date & time for submission of e-Bids.
- 18.6 No e-Bid can be resubmitted subsequently after the deadline for submission of e-Bids.

(C) e-Bid OPENING AND EVALUATION OF e-Bid

19(A) Opening of Technical e-Bid by the Purchaser

19.A-1 The Purchaser will open all technical e-Bids, in the presence of technical committee at 11:15AM on 29/02/2024 U.P. Co-operative Sugar Factories Federation Ltd, 9-A, Rana Pratap Marg, Lucknow. In the event of the specified date of e-Bid opening being declared a holiday for the Purchaser, the e-Bids shall be opened at the appointed time and place on the next working day.

19.A-2 The name of such bidders not meeting the Technical Specifications and qualification requirement shall be informed by e-mail/telephone call subsequently.

19.A-3 The Purchaser will prepare minutes of the e-Bid opening.

19 A-4 Managing Director reserves the right to postpone the date and time of opening of Technical & Financial E-Bid in unavoidable circumstances and all the bidders will be informed.

19(B) Opening of Financial e-Bid

19.B.1 After evaluation of technical e-Bid, the Purchaser shall notify those bidders whose technical e-Bids were considered non-responsive to the Conditions of the Contract and not meeting the technical specifications and Qualification Requirements indicating that their financial e-Bids will not be opened. The Purchaser will simultaneously notify the bidders, whose technical e-Bids were considered acceptable to the Purchaser. The notification may be sent by letter, fax or by e-mail.

19.B.2 The financial e-Bids of technically qualified bidders shall be opened on 29/02/2024 at 3:00PM in presence of purchase committee.

19.B.3 The Purchaser will prepare the minutes of the e-Bid opening.

20 Clarification of e-Bid

20.1 During evaluation of e-Bid, the Purchaser may, at its discretion, ask the bidder for a clarification of his/her e-Bid. The request for clarification and the response shall be in writing.

21 Evaluation of technical e-Bid and Evaluation Criteria

The Purchaser will examine the e-Bid to determine whether they are complete, whether they meet all the conditions of the Contract, whether required e-tender fee, e-Bid EMD and other required documents have been furnished, whether the documents have been properly digitally signed, and whether the e-Bids are generally in order. Any e-Bid or e-Bids not fulfilling these requirements shall be rejected.

The bidders shall submit the scanned copies of following as documentary proof for evaluation of their technical e-Bids.

(i) Bidder/supplier has to submit the order copy of CHAIN AND CHAIN SPARES in last five years to sugar mill minimum 2 order copy cooperative of any state / private sector. If the supplier/bidder is registered with M.S.M.E/Startup, may submit the such order copies for only one year of material supplied to participate in the e-tender.

- (ii) **Satisfactory performance certificate for of CHAIN AND CHAIN SPARES, in last five years to sugar mills minimum 2 performance certificate of state co-operative mill/private sector.** If the supplier/bidder is registered with M.S.M.E/Startup, may submit the such performance certificate for only one year of material supplied to participate in the e-tender.
- A. The bidder shall submit the copies of the detail of Tender Fee and E.M.D. if the bidder has not submitted the details of tender fees or E.M.D. or both, the bid will be rejected.
 - B. The bidder should quote for all items listed in BOQ and submit affidavit for same in technical bid otherwise bid will be automatically disqualified.
 - C. The bidder shall submit the copies of registration certificate of industries department of the state for supply of Chain and their spares.
 - D. The bidder shall submit copy of last audited balance sheet certified by C.A. with UDIN number.
 - E. The bidder / supplier not registered with MSME has to have annual turnover report duly certified by C.A. of last 3 years which must be not less than rupees 1 crore. UDIN number of CA is essential.
 - F. As per circular of Govt. of India dated 10.03.2016 to encourage the small firms registered in MSME/startup, a relaxation in annual turnover may be granted. In the above reference firms registered with MSME/startup with the average annual turnover of Rs50 lakh minimum will be accepted. Turnover certificate duly certified by chartered accountant with the UDIN number of CA is essential.
 - G. As per the circular of Govt. of India dated 10-03-2016, 20-09-2016 & 25-07-2016 to encourage the small firm registered in M.S.M.E/Startup, a relaxation in annual turnover may be granted in the above reference firm registered with M.S.M.E./Startup with annual turnover for one year only for the amount mentioned in the above para.
 - H. The bidder shall submit the copies of the last submitted Income Tax Return & PAN card (copy self attested).
 - I. **The bidder shall submit the copies of the details of GST registration.**
 - J. The bidder shall submit the documentary proof of the Status of the company along with names of Directors/Partners/Proprietor along with documents.
 - K. The bidder/supplier shall submit the copy of Aadhaar Card of all partners and authorized person if any.
 - L. The bidder shall submit affidavit in relation to the e-tender for debar and integrity (IP) as per attached proforma on Rupees One Hundred Non – Judicial stamp paper.
 - M. The e-Bids found to be not responsive to and not fulfilling all the conditions of the contract and not meeting Technical Specifications and Qualification Requirements to

the satisfaction of Purchaser shall be rejected and may not be subsequently made responsive by the bidder by correction of the non-conformity. The e-Bids of bidders mentioning any of their conditions which are not mentioned in the e-tender document or are not in conformity with the conditions of the contract shall be rejected.

- N. It shall be the discretion of the Purchaser to decide as to whether an e-Bid fulfils the evaluation criterion mentioned in this e-tender or not.
- O. The bidders are advised not to mix financial bid documents with the PDF documents submitted for technical bid. The e-Bids of the bidders having financial bid document in the technical bid will out rightly be rejected.
- P. The bidder shall submit copy of last audited balance sheet.

22 Financial Evaluation and Comparison of e-Bid

- 22.1 The Purchaser will evaluate and compare the financial rates of individual items quoted in the price schedule/BOQ of e-Bids of those bidders whose technical e-Bids are found responsive as per the conditions of the e-tender only for those items of the bidders which have been technically accepted by the Purchaser.
- 22.2 No additional payments shall be made for completion of any contractual obligation beyond the quoted prices. If the supplier does not accept the correction of errors if any, its e-Bid shall be rejected and its e-Bid security may be forfeited.
- 22.3 No weightage/preference shall be given to the bidder quoting any higher technical specifications against the technical specifications of the items asked in the e-tender.
- 22.4 The Purchaser's evaluation of Financial bid shall be based on basic Rate/Price quoted by Bidder. The price of incidental services, freight, insurance and other costs within India incidental to the delivery of the goods to their final destination shall be as mentioned in Para 8.2 of ITB
- 22.5 The Financial Bids will be opened by Tender Evaluation committee (TEC) Bid opening on date and time to be communicated to all the technically qualified Bidders.**The commercial quotes of the lowest Bidder shall be notified as L-1. The Quantity offered by the L-1 shall be first taken into consideration.**
 - a) In case L-1 offers to supply the complete order quantity and is assessed to have the adequate capacity to supply the complete order quantity as per the delivery schedule by the Tender Evaluation committee (TEC) then L-1 shall be contracted to execute the complete supply order.
 - b) In case L-1 offers to supply partial order quantity and is assessed to have adequate capacity to supply the offered partial order quantity as per the delivery schedule by the Tender Evaluation committee(TEC) then the L-1 bidder shall be contracted to supply the reduced quantity (which shall be more than the guaranteed minimum quantity) and rest of the quantity shall be allotted to subsequent bidder(s) provided the successful Bidder(s) are ready to offer the quantity at the rates quoted by L-1.
 - c) The quantity resulting from the split as mentioned above in case (b) shall be offered to the successful Bidder(s) after the assessment by the TEC in terms of their capacity to manufacture and supply.

- d) In case L-1 backs out, the RFP shall be cancelled & Bids shall be invited again L-1 shall however be blacklisted from participating in any future bidding and are liable for legal action taken by UPSUGAR FED.

23 **Contacting the Purchaser**

- 23.1 Subject to ITB Clause 20, no bidder shall contact the Purchaser on any matter relating to his/her e-Bid, from the time of the e-Bid opening to the time the Contract is awarded. If the bidder wishes to bring additional information to the notice of the Purchaser, he/she can do so in writing.
- 23.2 Any effort by a bidder to influence the Purchaser in its decisions on e-Bid evaluation, e-Bid comparison or contract award may result in rejection of the bidder's e-Bid.

(D) AWARD OF CONTRACT

24 **Award Criteria**

- 24.1 The Purchaser will determine to its satisfaction whether the bidder(s) that is selected as having submitted the lowest rate (L-1) evaluated responsive bid meets the criteria specified in ITB Clause 10.2, and is qualified to perform the contract satisfactorily.
- 24.2 Subject to ITB Clause 26, the Purchaser will award the contract to the lowest rate (L-1) evaluated successful Bidder whose bid has been determined to be responsive to all the conditions of the contract and meeting the Technical specification and qualification requirement of the Bidding Document.

25 **Purchaser's right to vary Quantities at the Time of Award**

- 25.1 The Purchaser reserves the right at the time of Contract award to increase or decrease the quantity of goods and services originally specified in the Schedule of Requirements without any change in unit price or other terms and conditions, depending upon the requirement of end-customer. The purchaser may also increase or decrease the quantity even after award of contract up to the validity period of E-bid.
- 25.2 If GST is increased/ decreased by the Government during the contract period, the same shall be adjusted mutually after submitting the proof by the successful bidder to the Purchaser.

26 **Purchaser's right to accept any e-Bid and to reject any or all e-Bids**

- 26.1 The Purchaser reserves the right to accept or reject any e-Bid, and to annul the e-Bid process and reject all e-Bids at any time prior to contract award, without thereby incurring any liability to the affected bidder or bidders.

27-Notification of Award

- 27.1 The Purchaser will notify the successful bidder in writing by letter/e-mail/fax, that its e-Bid has been accepted. Normally it will be informed within 30 days after opening of E-commercial/financial bid except in unavoidable circumstances.
- 27.2 The notification of award will constitute the formation of the Contract.
- 27.3 **Successful bidder's will have to deposit equal amount security money in addition to E.M.D.**

28 Signing of Contract

At the same time as the purchase notifies the successful bidder that its bid has been accepted, the purchaser will inform the bidder accordingly

29 Performance/ Supply Security

The successful bidder shall deposit the security money as equal amount of E.M.D. No interest will be paid on security. The security deposited with Federation shall be subjected to timely & satisfactory supply of ordered quality of material along with satisfactory performance from sugar factory and full & final adjustment of claims/dues of our units recoverable from them after deducting penalty if any, under these terms.

SECTION II: CONDITIONS OF E-Tender/CONTRACT (CC)

Only manufacturers fulfilling the required conditions of tender document are eligible to participate in the tender.

1. Price

- (i) The basic price should be quoted by the bidders on **Ex works** basis. This will include basic price, packing and forwarding, Insurance charges, and **excluding GST and Transportation Charges**. The supplier is required to submit the relevant documents to avail Input Tax Credit.
- (ii) The final rates mentioned in the E-Bid shall remain firm for the crushing season **2024-25 i.e. upto 30/06/2025**.
- (iii) Any change in the rate of GST by the GOVT may be accepted provided documentary proof of the same is submitted for approval.

2. DESPATCH OF MATERIAL

- (i) The material should be dispatched as per instructions given by the mill society. The material sent by Road Transport should be sent through the reputed Bank approved transport Co. and duly covered with transit Insurance. Seller will ensure that the goods are insured to avoid any loss or damage during transit.
- (ii) The supply of material shall made as per quantitative requirement and specifications given in the order. The excess quantity of supply will not be accepted and will have to be taken back by the supplier at their own cost and risk.

3. Earnest money

Each bidder should submit RTGS/ NEFT/ NET BANKING for Rs. 75000/- (Seventy five Thousand Only) in favour of U.P. Cooperative Sugar Factories Federation Ltd, payable at Lucknow representing earnest money. The tenders without earnest money as above shall not be entertained (Central/State Government agencies or organizations are exempted from the requirement of EMD)

4. **Security Money**

Successful bidder shall have to deposit the security amount as equal to EMD amount. No interest shall be paid on the security deposit. The refund of the security deposit shall be subject to timely and satisfactory supply of ordered quantity of **Chain and their spares** and on full and final adjustment of claims/dues of our units recoverable from them after deducting penalty, if any under these terms.

5. **PACKING & FORWARDING:**

The material should be packed in secured and sound packing to avoid any damage during the transit. The packing list shall be kept inside each packet.

6. **Payment Terms:**

10% advance against bank guarantee and balance 90% against delivery of material/Performa Invoice..

7. **Inspection & Rejection**

- (i) The material should strictly conform to the specifications given in the rate contract/order. The authorized representative of the Federation/Mill Society may inspect the material at supplier works/godown before taking delivery. The supplier has to provide all facilities in the process of inspection.
- (ii) The sub-standard material and material not conforming to the specifications will be rejected by the mill society. The supplier will arrange the transport of rejected material at their own cost and risk within 15 days from the factory premises.
- (iii) For checking of the genuineness of the material, the sample may be taken out and sent to **inspecting agency/laboratory**. In case the supplied material is found spurious, the same shall be returned by the mill society. The loss on account of cost of material along with interest @18% shall be recovered from the party. Action for Black listing the supplier may also be taken.

8. **SANCTITY**

The Purchase order is final agreement between supplier and the mill society. Any terms and conditions of enquiry/letter, tender /quotation or any other documents inconsistent with the terms of purchase order will have no effect and will be null and void.

9. **Delivery & Penalty:**

- (i) Delivery period should be as given in our tender document for a particular item. The material should be supplied within this period which will be counted from the date of issue of commercially and technically clear order by the mill societies as per the terms of Rate Contract.
- (ii) If the material is not delivered within stipulated period, the buyer reserves the right to return the goods at the cost and expenses of the supplier and shall recover all losses made in arranging supplied from other sources. The buyer also reserves the

right to cancel the order and may claim all the amount paid against the order together with interest along with all expenses incurred by the buyer in addition to the loss mentioned above.

(iii) There will be late penalty of 1% of total cost of material in case of delayed supply upto 01 week. If the supply delayed upto 02 weeks, penalty will be 5% of the total cost. If the supply delayed upto 03 weeks, penalty will be 10% of the total cost. In case the supply of material delayed more than 3 weeks concerned firm will be black listed.

(iv) Failure to supply and risk purchase clause:-

If the supplier fails to supply any store material in accordance with the terms and conditions as provided in the Rate contract or fails to replace the material rejected by the sugar factories, within the time stipulated the sugar factories shall at the risk and cost of supplier and without any notice or reference to him be entitled to purchase stores (of the same specifications) from any other source and at such price as the sugar factories shall in their sole discretion think fit and if such price shall exceed the rate set out in the rate contract, the supplier shall be liable to pay the sugar factory, the difference between the price at which such stores have been purchased by the sugar factories and at the price set out in the rate contract in addition to penalty and damages as set out in the rate contract.

10. **Variation**

The Rate contract/Order do not provide any right to supply for a particular quantity and the Purchaser may vary the quantity as per assessment of requirement and also change the delivery schedule in exigency without giving any notice to the Supplier.

11. **Arbitration**

Solely for the purposes of settlement of any dispute arising between the parties out of this agreement, the contractor shall be treated as an agent of the mill and any dispute arising out and between the parties to this agreement shall be referred to arbitration to the Registrar in accordance with Section 70 of the U.P. Cooperative Societies Act, 1965.

12. In case of non compliance of the conditions of the contract the Managing Director of Federation shall have the power to rescind, cancel and annul the contract, between the Purchaser and the Supplier apart from black-listing the Supplier, and in that event, the sum deposited towards security shall be forfeited and the Supplier shall be further liable to pay actual amount of loss and damages as provided in Indian Contract Act to U.P. Cooperative Sugar Factories federation Ltd to the extent the same exceeds the security money.
13. The bidders who are awarded with the rate contract/ order shall supply the material directly to our mill societies and in no case they shall be allowed to appoint their dealers for supply of material. The manufacturers, who do not supply the material directly, may direct their dealers to participate in the tender and obtain rate contract/order directly from Federation. However material has to be dispatched from Principal's Godown directly.
14. In case of any dispute between the Supplier and buyer the Hon'ble Allahabad High Court of judicature at Lucknow and Courts sub-ordinate there to of the District in which the mill is situated shall alone have jurisdiction to the exclusion of all other courts.

15. In complete tender or those without the prescribed EMD may be rejected.
16. The supplier should be registered with the GST department so that they may provide INPUT TAX CREDIT for the items on which the same is available. They will provide all necessary documents such as GST Invoice etc to our mill societies for enabling them to claim INPUT TAX CREDIT from the GST Department wherever applicable. In case of GST included in rates then the related documents will have to be furnished by the party, failing which amount of GST as per prevailing rate/rates will be deducted from payment made by the factory.
17. The Purchaser reserves the right to reject any or all tenders without assigning any reason. The Purchaser also reserves the right to amend or altogether change the terms & conditions in the overall interest of the Organization before finalization of the Purchase order.
18. The bidder should mention the warranty period of items to be supplied to our mill society. In case the supplied materials fails within this stipulated period, the same shall be replaced by the supplier on free of cost basis.
19. Validity of Rate Contract – Up to 30/06/2025
20. Warranty Period -One Crushing Season.
21. The manufacturers are directed to furnish the test report for the composition and breaking strength of the material to be supplied to the mills. In case sub standard material is reported by the mill, strict action against the manufacturer shall be taken by way of recovery of amount and black listing of the party for future dealings. Tensile strength and material composition (Metallurgical) certificate will have to be furnished by the supplier to the mill society.
22. All the supplied material are to be tested for its composition in a reputed & government approved laboratory /test house & the sample's shall be taken randomly by factory committee (if the supplier wants his representative can also be present during sampling item). If the deviation in the composition of material is upto 5% than the standard, the EMD and security would be forfeited and if the deviation is more than 5%, the supplier will be debarred for two years along with forfeiting of E.M.D and security.
23. The bidder should enclose a list of machinery in their works along with capacity of manufacturing.
24. The bidder should have case hardening and tempering facility by cyanide bath process for which details to be furnished along with the tender.
25. The tender having no details of correct metallurgy and specifications are liable to be rejected during Technical discussions.
26. The printed literature/catalogue of the items (Product) offered by the bidder should be attached with the tender to assess the technical suitability of the firm.
27. The bidder should submit affidavit for in relation to the E-Tender Form Debar and integrity pact (IP) as per attach Performa on Rs.100 Non judicial stamp paper to be uploaded E Tender and hardcopy to be sent through courier/ by post.
29. **The supplier should produced test certificate of the supplied material from the reputed test laboratories to the Sugar Mill.**

30. **The Sugar Mills have to get tested every Supplied material from reputed test laboratories / origination. In case of getting below Standard report of supplied items blacklisting of supplier will be executed.**
- 31 The Bidder shall upload all required documents strictly at the time of filling e- Tender. No physical document will be accepted at any case during the Tender Process.
- 32 Preference is given to supply of ISI marked item.(where applicable). It is mandatory to submit the required proof by the Supplier/bidder.
- 33 If a new company/firm participate in the e-tender proceeding for Chain and their spares work the firm's turnover purchase order and performance will be tested by the technical committee. Post-trial, if found successful from technical point of view, in the first year, a maximum of 2 sugar mill will be trialed and regular rate contracts will be considered in the coming years, if the performance of the supplied material is satisfactory.
- 34 If required L-1 bidder will be called for necessary negotiation afterwards.
- 35 After the finalization of rate contract the copy of the said rate contract, will be sent to the concerned supplier & all 24 mills vide e-mail & same will be uploaded on e- tender portal.
- 36 If in any case any bidder/supplier impose undue influence (Convincing) in that case the concerned bidder/supplier will be debarred for next 3 years to participate in any tender process of Federation.
- 37 Any bidder/Supplier are disputed in court not participate in Federation tender.
38. The L1 bidder will be selected on the following criteria:-
a) For Cane Carrier Chain – Combined/Total of rates quoted for M.S. Roller, Pin, Bush, Side Bar Link and M.S. Plate.
b) For Bagasse Carrier Chain - Combined/Total of rates quoted for M.S. Roller, Pin, Bush, Side Bar Link, Side Bar Attachment and A.S. Swivelled Attachment.
39. **Rate contract would be awarded to maximum 10 bidders participated in the E bid. L-1 bidder will be decided in the following way- For example if a bidder is having L-1 rates in 100 items out 125 items, he would be awarded as L-1 bidder. Consequently depending on the number of items having lowest rates, would be awarded as L-2, L-3,L-4 & so on.**

GENERAL MANAGER (P)

SECTION III: TECHNICAL E-BID

- III(A) e Bid FORM**
- III(B) SCHEDULE OF REQUIREMENTS**
- III(C) TECHNICAL SPECIFICATIONS**
- III(D) CONTRACT FORM**
- III(E) PERFORMANCE STATEMENT**
- III(F) CAPABILITY STATEMENT**
- III(G) PERFORMANCE SECURITY FORM**

SECTION III(A): e- bid FORM

Date:.....

IFB No UPSUGARFED/CHAINSPARES/2024-25/ P-10874

To:

The Managing Director,
U.P. Cooperative Sugar Factories federation Ltd,
9-A, Rana Pratap Marg
Lucknow(U.P)-226001

Dear Sir,

Having examined the e-Bid Documents, we, the undersigned,offer to deliver.....

(Description of Goods and Services) in conformity with the said e-Bid(Section II) of the e-Bid Document and will supply of **Chain and their spares** from our manufacturing works/units as per specifications (Section III(c)) to your factories in addition to this, the particulars of our organization such as legal status, details of experience and past performance, capability statement and the required e-Bid EMD for Rs. **75000/- (Seventy five Thousand Only)** in the form of RTGS/ NEFT/ NET BANKING in favour of U.P.Cooperative Sugar Factories Federation Ltd, Lucknow, is furnished with this e-Bid form.

We further undertake, if our e-Bid is accepted, to deliver the **Chain and their spares** in accordance with the delivery schedule specified in the Schedule of Requirements (Section III (B)).

We agree to abide by this e-Bid for the e-Bid validity period specified in Clause 13.1 of the ITB and it shall remain binding upon us and may be accepted at any time before the expiration of that period.

Until a formal contract is prepared and executed, this e-Bid, together with your written acceptance thereof and your notification of award shall constitute a binding contract between us. All the terms and conditions of the e-tender Document are acceptable to us.

We undertake that, in competing for (and, if the award is made to us, in executing) the above contract, we will strictly observe the laws against fraud and corruption in force in India namely “Prevention of Corruption Act 1998”.

We understand that you are not bound to accept the lowest or any e-Bid you may receive.

Dated this.....day of20.....

Signature

(in the capacity of)

Duly authorized to sign e-Bid for and on behalf of

SECTION III(B): SCHEDULE OF REQUIREMENTS

Item Code	Brief Description	Destination	Delivery Schedule	e-Bid E.M.D
	As per the details given in the SECTION III (C) TECHNICAL SPECIFICATIONS	Various sugar Factories of UP co-op. sugar Factories Federation Ltd. located in different parts of U.P.	. To be dispatched within 8-10 weeks or as per requirement from receipt of order .	Rs 75000/-

SECTION III (C) TECHNICAL SPECIFICATIONS

A. Specifications

Sl. No.	Particulars
1	2
1.	Cane carrier chain No. 9060 with 150mm/152.4mm standard pitched fitted with case Hard ened MS Roller & EN-9/EN-8D Bush & Pin Suitable for 40 tonnes breaking load
2.	Cane carrier chain No. 9060 with 150mm/152.4mm standard pitched fitted with case Hard ened MS Roller & EN-9/EN-8D Bush & Pin Suitable for 60 tonnes breaking load
3.	fitted with case Hardened MS Roller & EN-351/SAE8620 Pin & Bush Suitable for 40 tonnes breaking load
4.	fitted with case Hardened MS Roller & EN-351/SAE8620 Pin & Bush Suitable for 60 tonnes breaking load
5.	Cane carrier chain 200 mm pitch Fitted with case hardened MS roller, EN-351/SAE8620, Pin & EN-351/SAE8620 Bush as per drawing Conforming to IS-8415:1990/91 and amended upto date Suitable for 60 tonnes breaking load
6.	Cane carrier chain parts As per mill drawing Suitable for 40 tonnes with 150 mm/ 152.4mm standard pitch MS Roller case hardened
7.	Cane carrier chain parts As per mill drawing Suitable for 60 tonnes with 150 mm/ 152.4mm standard pitch MS Roller case hardened
8.	Cane Carrier chain parts suitable for 40 tonnes pitch 150 mm/ 152.4mm Bush duly hardened tempered & ground EN-351/SAE8620
9.	Cane Carrier chain parts suitable for 60 tonnes pitch 150 mm/ 152.4mm Bush duly hardened tempered & ground EN-9/EN-8D
10.	Cane Carrier chain parts suitable for 60 tonnes pitch 150 mm/ 152.4mm Bush duly hardened tempered & ground EN-351/SAE8620
11.	Cane carrier pin duly hardened & tempered and ground suitable for 40 tonnes EN-351/SAE8620
12.	Cane carrier pin duly hardened & tempered and ground suitable for 60 tonnes EN-351/SAE8620
13.	Cane Carrier chain side bar link carbon steel hardened & tempered Suitable for 40 tonnes breaking load
14.	Cane Carrier chain side bar link carbon steel hardened & tempered Suitable for 60 tonnes breaking load
15.	Cane carrier chain part 200 mm pitch chain as per mill drawing Suitable for 60 tonnes breaking load MS Roller case hardened
16.	Cane carrier chain part 200 mm pitch chain as per mill drawing Suitable for 60 tonnes breaking load Bush duly hardened tempered and ground EN-351/SAE8620
17.	Cane carrier chain part 200 mm pitch chain as per mill drawing Suitable for 60 tonnes breaking load Pin duly hardened tempered and grounded EN-351/SAE8620
18.	Cane carrier chain part 200 mm pitch chain as per mill drawing Suitable for 60 tonnes breaking load Side bar link carbon steel hardened and tempered

19.	Bagasse carrier chain with MS case hardened roller EN-9/EN-8D, side plate and EN-9/EN-8D Pin/Bush pitch 152.4 mm hardened and tempered at every 4th link Attachment Suitable for 40 Tons breaking load
20.	Bagasse carrier chain with MS case hardened roller EN-9/EN-8D, side plate and EN-351/SAE8620 Pin/Bush pitch 152.4 mm hardened and tempered at every 4th link Attachment Suitable for 60 Tons breaking load
21.	Bagasse carrier chain with MS case hardened roller EN-9/EN-8D, side plate and EN-351/SAE8620 Pin/Bush pitch 152.4 mm with AS-2 swilled attachment with pin of carbon steel hardened and tempered at every 4th link Suitable for 60 Tons breaking load
22.	Bagasse carrier chain with MS case hardened roller, EN-9/EN-8D side plate, EN-351/SAE8620 Pin & EN-351/SAE8620 bush pitch 200 mm with AS-2 swilled attachment with Pin of carbon steel hardened & tempered at every 4th link Suitable for 60 Tons breaking load
23.	Bagasse carrier chain parts as per Mill drawing suitable for 40 Tons pitch 152.4 mm as per drawing MS roller case hardened & ground
24.	Bagasse carrier chain parts as per Mill drawing suitable for 40 Tons pitch 152.4 mm as per drawing Pin EN-351/SAE8620 duly hardened tempered & ground
25.	Bagasse carrier chain parts as per Mill drawing suitable for 40 Tons, pitch 152.4 mm as per drawing Bush EN-351/SAE8620 duly hardened, tempered and ground
26.	Bagasse carrier chain parts as per Mill drawing suitable for 60 Tons pitch 152.4 mm as per drawing MS roller case hardened & ground
27.	Bagasse carrier chain parts as per Mill drawing suitable for 60 Tons pitch 152.4 mm as per drawing Pin EN-351/SAE8620 duly hardened tempered & ground
28.	Bagasse carrier chain parts as per Mill drawing suitable for 60 Tons pitch 152.4 mm as per drawing Bush EN-351/SAE8620 duly hardened, tempered and ground
29.	Bagasse carrier chain side bar link of carbon steel hardened and tempered, Pitch 152.4 mm as per drawing - 40 Tons
30.	Bagasse carrier chain side bar link of carbon steel hardened and tempered, Pitch 152.4 mm as per drawing - 60 Tons
31.	Bagasse carrier chain side attachment Link of carbon steel hardened and tempered Pitch 152.4 mm as per drawing - 40 Tons
32.	Bagasse carrier chain side attachment Link of carbon steel hardened and tempered Pitch 152.4 mm as per drawing - 60 Tons
33.	AS-2 swilled attachment with pin of carbon steel hardened & tempered Suitable for 40 Tons, Pin 152.4 mm
34.	AS-2 swilled attachment with pin of carbon steel hardened & tempered Suitable for 60 Tons, Pin 152.4 mm
35.	Bagasse carrier chain parts as per Mill drawing suitable for 60 Tons breaking load pitch 200 mm conforming to IS code-8466 - MS Roller cased hardened & ground

36.	Bagasse carrier chain parts as per Mill drawing suitable for 60 Tons breaking load pitch 200 mm conforming to IS code-8466 - Bush EN-351/SAE8620 duly hardened, tempered and ground
37.	Bagasse carrier chain parts as per Mill drawing suitable for 60 Tons breaking load pitch 200 mm conforming to IS code-8466 - Pin EN-351/SAE8620 duly hardened, tempered and ground
38.	Bagasse carrier chain parts as per Mill drawing suitable for 60 Tons breaking load pitch 200 mm conforming to IS code-8466 - Side bar link of carbon steel hardened and tempered
39.	Bagasse carrier chain parts as per Mill drawing suitable for 60 Tons breaking load pitch 200 mm conforming to IS code-8466 - Side attachment link of carbon steel hardened and tempered
40.	Bagasse carrier chain parts as per Mill drawing suitable for 60 Tons breaking load pitch 200 mm conforming to IS code-8466 - AS-2 swilled attachment with pin of carbon steel hardened & tempered
41.	Forged steel intercarrier chain with bush Pin and split Pin, Chain No - 902
42.	Forged steel intercarrier chain with bush Pin and split Pin, Chain No - 907
43.	Spares for intercarrier chain MS Pin 16.0 mm
44.	Spares for intercarrier chain MS Bush 22.0 mm
45.	Spares for intercarrier chain MS Pin 17.6 mm
46.	Spares for intercarrier chain MS Bush 24.2 mm
47.	Forged steel Rake carrier chain 200 mm pitch suitable for breaking load of 60 Tons, minimum with nyloc Nut or check nut locking arrangement with SS Pin & SS Bush - Block type made of 45 C8 steel
48.	Forged steel Rake carrier chain 200 mm pitch suitable for breaking load of 60 Tons, minimum with nyloc Nut or check nut locking arrangement with SS Pin & SS Bush - Plate Type
49.	Forged steel rake carrier chain 229 mm pitch suitable for breaking load 60 Tons minimum with nyloc nut or check nut locking arrangement with SS Pin and SS Bush - Block type made of 45 C8 steel
50.	Forged steel rake carrier chain 229 mm pitch suitable for breaking load 60 Tons minimum with nyloc nut or check nut locking arrangement with SS Pin and SS Bush - Plate Type
51.	Forged steel rake carrier chain 300 mm pitch suitable for breaking load 75 Tons minimum with nyloc nut or check nut locking arrangement with alloy steel pin and alloy steel Bush - Block type made of 45 C8 quality steel
52.	Rake carrier chain spares 200 mm pitch - Pin with nyloc nut (SS) - Block Type
53.	Rake carrier chain spares 200 mm pitch - Bush (SS) - Block Type
54.	Rake carrier chain spares 200 mm pitch - Link with attachment (MS) - Block Type
55.	Rake carrier chain spares 200 mm pitch - Link (MS) - Block Type
56.	Rake carrier chain spares 200 mm pitch - Pin with nyloc nut (SS) - Plate Type

57.	Rake carrier chain spares 200 mm pitch - Bush (SS) - Plate Type
58.	Rake carrier chain spares 200 mm pitch - Link with attachment (MS) - Plate Type
59.	Rake carrier chain spares 200 mm pitch - Link (MS) - Plate Type
60.	Rake carrier chain spares 200 mm pitch - Roller case hardened (MS) - Plate Type
61.	Rake carrier chain spares 229 mm pitch - Pin with nyloc nut (SS) - Block Type
62.	Rake carrier chain spares 229 mm pitch - Bush (SS) - Block Type
63.	Rake carrier chain spares 229 mm pitch - Pin with nyloc nut (SS) - Plate Type
64.	Rake carrier chain spares 229 mm pitch - Bush (SS) - Plate Type
65.	Rake carrier chain spares 229 mm pitch - Link with attachment (MS) - Plate Type
66.	Rake carrier chain spares 229 mm pitch - Link (MS) - Plate Type
67.	Rake carrier chain spares 229 mm pitch - Roller case hardened (MS) - Plate Type
68.	Rake carrier chain spares 300 mm pitch block type breaking load 75 Tons minimum - Pin (SS)
69.	carrier chain spares 300 mm pitch block type breaking load 75 Tons minimum - Bush (SS)
70.	Rake carrier chain spares 300 mm pitch block type breaking load 75 Tons minimum - Link with attachment (MS)
71.	Rake carrier chain spares 300 mm pitch block type breaking load 75 Tons minimum - Link (MS)
72.	Malleable Iron chain No-503 for Sugar elevator with attachment Link No. G-20 after 5th link
73.	MS fabricated chain for feeder table having strand of 150 mm pitch heavy duty. Drawing . Type suitable for breaking strength of 40,000 Kgs minimum
74.	MS Slates (Thickness - 5 mm/6mm) - Cane Carrier
75.	Bagasse Carrier chain 150 mm pitch suitable for 50 ton breaking load as per drawing with AS-2 Swivel attachment link drawing no. SE/4407/150(RevO)
76.	Spare for above Above-Roller(EN-8D) drg SG 001
77.	Spare for Above-Bush Plain(EN-353) drg.SG002
78.	Spare for above-Pin step thread(EN-353) drg SG003
79.	Spare for above –Swivel link(IS 2062) drg SG 015
80.	Cane Carrier chain no.9060 with 150 mm standard pitch fitted with EN-353 Pin & bush for 60 Ton breaking load complete with Castle Nut and Split Pin as per Drg. No. SE/2246/150 Rev 01
81.	Block type rake carrier chain 229 mm pitch suitable for 80 Ton breaking load fitted with SS-410 pin & Bush and EN-9/EN-8D forged link as per our drawing no.SE-5329@229 Rev 02 Spare for above- Plain Bush small(SS-410) drg SG 002(A)
82.	Spare for above- Plain Bush big(SS-410) drg SG 003
83.	Spare for above-Pin threaded(SS-410) drg SG 003
84.	Spare for above-Castle Nut(M-30) srd Galvansied drg SG 012

85.	Cane Carrier chain no.9060 with 200 mm pitch fitted with EN-353 pin and Bush for 60 Ton breaking load complete with Castle Nut & split pin as per drawing no.KK1/CCC/RAMALA/2018 Rev.1
86.	Bagasse Carrier chain of 200 pitch, suitable for 60 tons breaking load, as per drawing no. KK1/BCC/RAMALA/2018 Rev.1 fitted with EN-353 pin and bush, Castle nut & split pin.
87.	Block type Rake Carrier Chain 229 mm pitch, suitable for Breaking load of 80 Ton, fitted with SS 410 pin and bush and EN-9/EN-8D, forged link, as per Drawing no. KK1/BFCD/RAMALA/2018 Rev.1 and M 30 Nylock Nut.
88.	Cane Carrier chain no.9060 with 200 mm pitch spares as per drawing no. KK1/CCC/RAMALA/2018 Rev.1 for 60 Ton breaking load. <ul style="list-style-type: none"> i) Rollers(EN-8D) ii) Bush(EN-353) iii) Pin (EN-353) step thread iv) Castle Nut(M.S 1” Size) v) Slates 75 nos. of wt.30 kg. Each, as per drawing No. RSML-MH-0301-01-100
89.	Bagasse Carrier Chain spares of 200 pitch, suitable for 60 tons breaking load as per drawing No. KK1/BCC/RAMALA/2018 Rev.1 <ul style="list-style-type: none"> i) Rollers(EN-8D) ii) Bush(EN-353) iii) Pin(EN-353) Step thread iv) Castle Nut(M.S 1” Size) v) Attachment link EN-9/EN-8D for Rake/Swivel Link(IS 2062) vi) Attachment PIN MS
90.	Block type Rake Carrier Chain 229 mm pitch, suitable for Breaking load of 80 ton spares as per Drawing No. KK1/BFCD/RAMALA/2018 Rev.1 <ul style="list-style-type: none"> i) Bush small(SS 410) ii) Bush Big(SS410) iii) Pin Threaded(SS 410) iv) Nut (M 30 Nylock)

SPECIFICATION AND DRAWING FOR SATHIAON CHINI MILL

THE KISAN SAHKARI CHINI MILLS LTD., SATHIAON (AZAMGARH)

Details of Chaians & Chain spares

1. Bagasse Carrier Chain 150 mm pitch suitable for 60 Ton Breaking Load as per drawing with AS-2 Swivel attachment link. (Drg. No. SE/4407/150 Rev 00)

Spares of above chain :-

	<u>Part code of above Drg.</u>
a. Roller (EN-8D) ?	SG 001
b. Bush Plain (EN-353)	SG 002
c. Pin Step Thread (EN-353)	SG 003
d. Side Link (EN-19) ?	SG 004, 5,6,7
e. Hex Nut (MS) ?	SG 012
f. Pin Swivel (20 MnCr5) ?	SG 014
g. Swivel link (IS 2062)	SG 015

2. Cane Carrier Chain No. 9060 with 150 mm Standard pitch fitted with EN-353 Pin & Bush for 60 Ton Breaking load complete with Castle Nut and Split Pin as per Drg. No. SE/2246/150 Rev 01.

Spares of above Chain :-

	<u>Part Code of above Drg.</u>
✓ a. Roller (EN-8D)	SG 001
✓ b. Bush Plain (EN-353)	SG 002
c. Pin Plain thread (EN-353)	SG 003
d. Side Link (EN-19)	SG 004, 7, 7(A)
e. Castle Nut (M-24) M.S.	SG 012

3. Block type Rake Carrier Chain 229 mm pitch suitable for 80 Ton Breaking load fitted with SS-410 pin & Bush and EN-9 forged link as per our drawing No. SE/5329/229 Rev 02.

Spares pf above Chain :

	<u>Part Code of above Drg.</u>
a. Plain Bush small (SS-410)	SG 002 (A)
b. Plain Bush big (SS-410)	SG 002 (B)
c. Pin threaded (SS-410)	SG 003
d. Forged link Plain (EN-9) ?	SG 008
e. Forged link attachment (EN-9) ?	SG 009
f. Castle Nut (M-30) Std. Galvanised	SG 012

Asst. Engineer

Chief Engineer

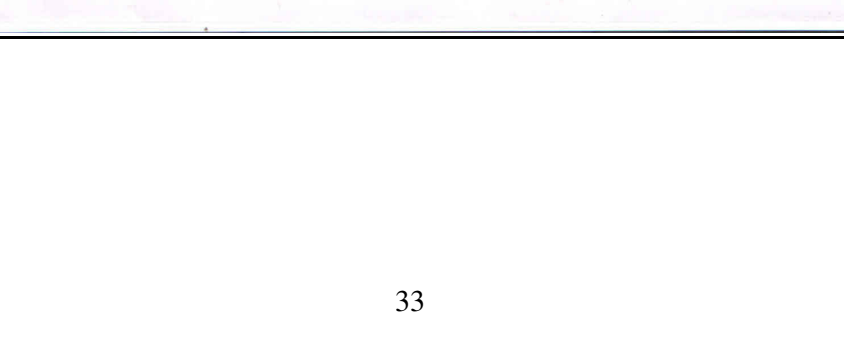
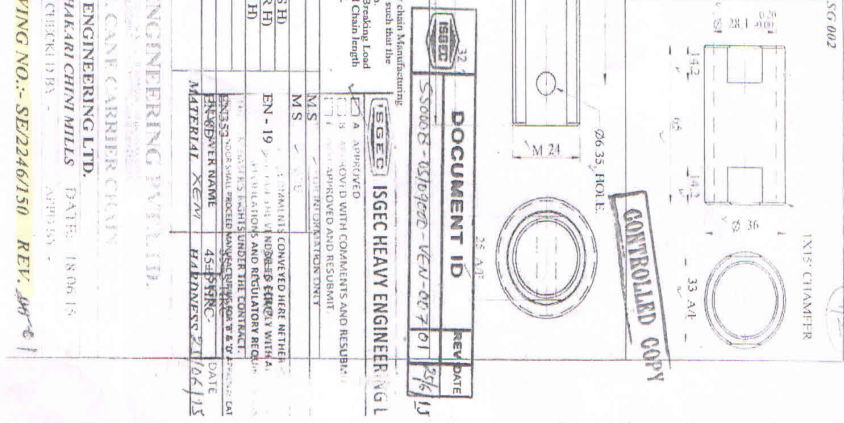
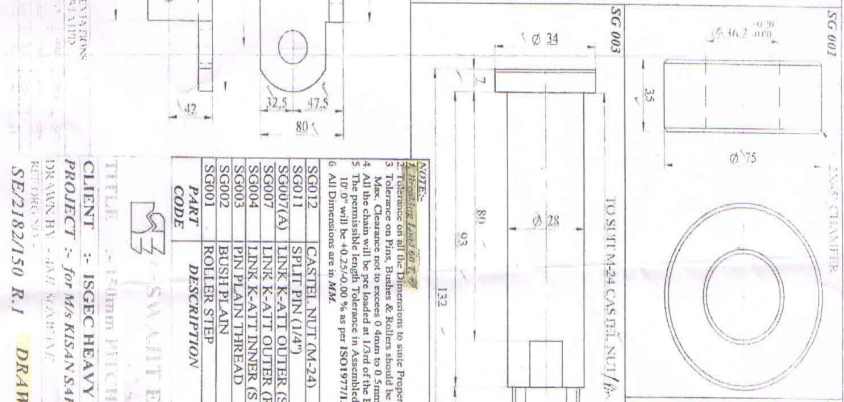
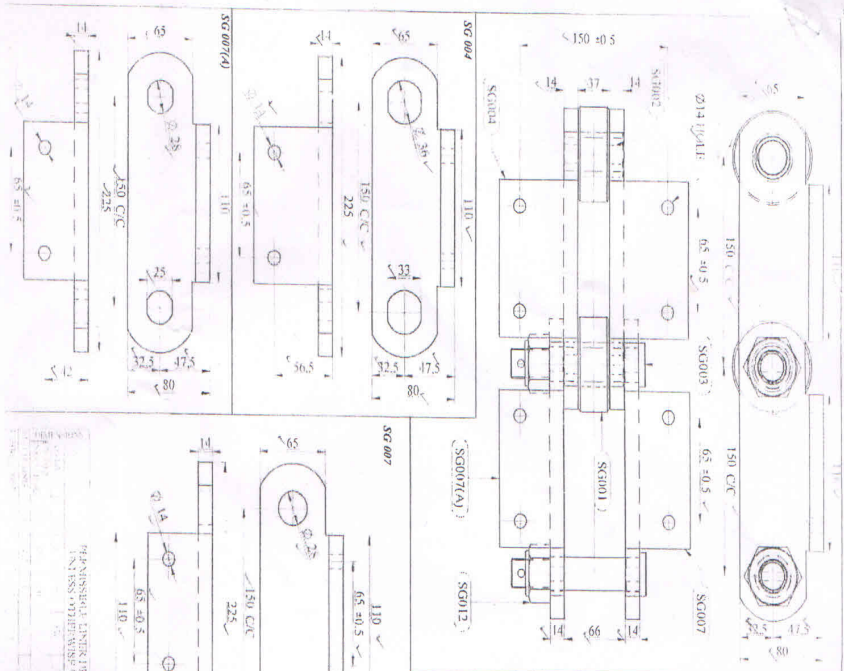

ISGEC
 ISGEC HEAVY ENGINEERING LTD.
 PAPERBAG, DURGAPUR, CHENNAI
 (INDIA) - 600 029
 DR. M. N. S. - JAWAHERLAL NEHRU UNIVERSITY
 CHENNAI - 600 097
 TEL: 044-26182150 R.1
 DATE: 18.06.15
 DRAWING NO.: SE/2246/150 REV. 1

NOTES:

1. All dimensions are in MM.
2. Tolerance on Pin, Studs & Rollers should be such that the Max. Clearance not to exceed 0.04mm to 0.05mm.
3. The permissible length Tolerance in Assembled Chain Length 10" will be +0.25/-0.00 % as per ISO19771.
4. All Dimensions are in MM.
5. The permissible length Tolerance in Assembled Chain Length 10" will be +0.25/-0.00 % as per ISO19771.
6. All Dimensions are in MM.

PART CODE	DESCRIPTION	MATERIAL	DATE
SG007	CASTEL NUT (M-24)	M S	
SG011	SPLIT PIN (1/4")	M S	
SG007(A)	LINK K-ATT OUTER (S.H)	EN - 19	
SG004	LINK K-ATT OUTER (R.H)	EN - 19	
SG002	LINK K-ATT INNER (S.H)	EN - 19	
SG001	LINK K-ATT INNER (R.H)	EN - 19	
SG001	ROLLER SHIP	45# STEEL	

ISGEC	DOCUMENT ID	REV	DATE
ISGEC	ISGEC HEAVY ENGINEERING LTD.		
	ISGEC HEAVY ENGINEER		
	28 APR 15		

CONTROLLED COPY

V S M Chidambaram

ISGEC HEAVY ENGINEERING PVT. LTD.

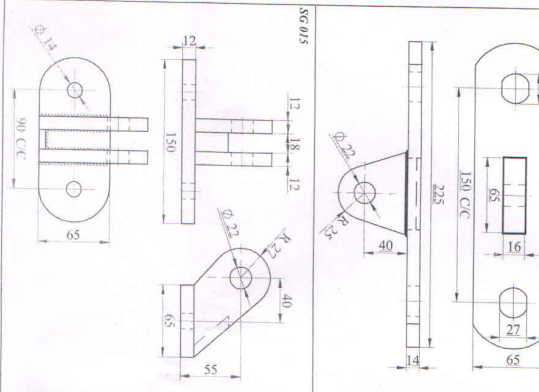
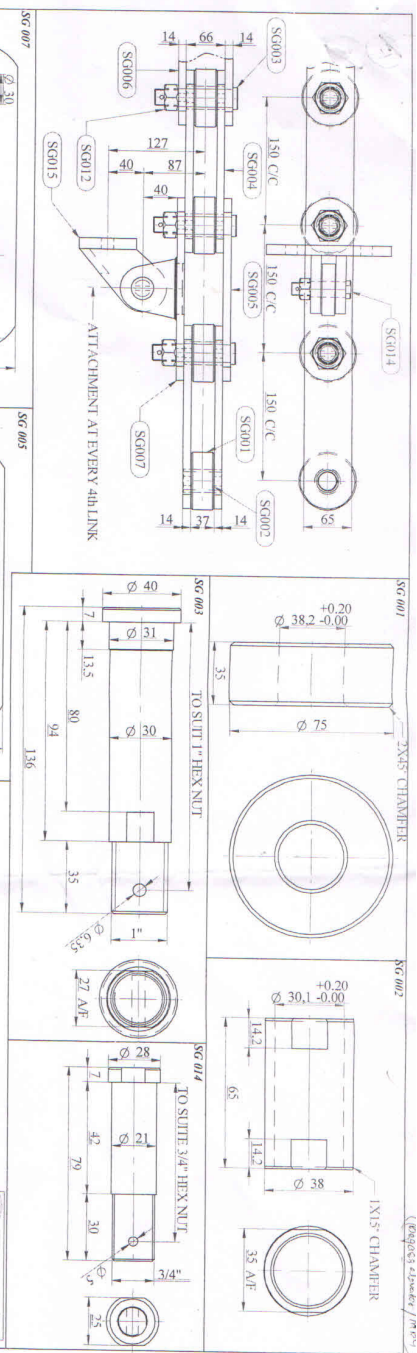

CODE	UNIT	QTY	DESCRIPTION
SCG001	LINK	6	LINK
SCG002	ROLLER	6	ROLLER
SCG003	SWIVEL LINK	6	SWIVEL LINK
SCG004	ROLLER	6	ROLLER
SCG005	LINK	6	LINK
SCG006	ROLLER	6	ROLLER
SCG007	SWIVEL LINK	6	SWIVEL LINK
SCG008	ROLLER	6	ROLLER
SCG009	LINK	6	LINK
SCG010	ROLLER	6	ROLLER
SCG011	LINK	6	LINK
SCG012	ROLLER	6	ROLLER
SCG013	LINK	6	LINK
SCG014	ROLLER	6	ROLLER
SCG015	LINK	6	LINK

NOTE:-

1. Breaking Load @ 1.2
2. Tolerance on all the Dimensions to suite Proper chain Manufacturing
3. Tolerance on Pins, Bushes & Rollers should be such that the Max. Clearance not to exceed 0.4mm to 0.5mm.
4. All the chain will be pre loaded at 1/3rd of the Breaking Load
5. The permissible length Tolerance in Assembled Chain length 10.0" will be +0.25/-0.00 % as per ISO19771.
6. All Dimensions are in MM.
7. Attachment At Every 4th Link. (Following).

PART CODE	DESCRIPTION	MATERIAL	HARDNESS
SCG015	SWIVEL LINK	IS 2062	
SCG014	PIN SWIVEL	20MNC5	
SCG012	HEX NUT (1" & 3/4")	MS	
SCG011	SPLIT PIN (1/4" & 3/16")	SS 304	
SCG007	LINK ATT OUTER (S/H)	EN-19	30±5 HRC
SCG006	LINK PLANS OUTER (S/H)	EN-19	30±5 HRC
SCG004	LINK ATT INNER (S/H)	EN-19	30±5 HRC
SCG003	LINK PLANS INNER (S/H)	EN-19	30±5 HRC
SCG002	PIN STEEL THREAD	SS 410/EN 353	43±5 HRC / 55±5 HRC
SCG001	ROLLER PLAIN	EN-8D	43±5 HRC

SWAJIT ENGINEERING PVT.LTD.
 KARNATAKA WELDING & FABRICATION WORKS
 HINDU INDUSTRIAL ESTATE, 2ND STAGE, LENOOR, CHANNarayana

TITLE :- 150mm PITCH BAGASSE CARRIER CHAIN

CLIENT :- ISGEC HEAVY ENGINEERING LTD.

PROJECT :- FOR MS KUSAN SAHAKARI CHINI MILLS

DRAWN BY :- ANIL SOMANE **CHECKED BY :-** **DATE:- 27.05.15**

REVISIONS:

NO.	DESCRIPTION	DATE
1	ISSUED FOR MANUFACTURE	27.05.15

DRAWING NO. :- SE/4407/150 **REV. :- 00**

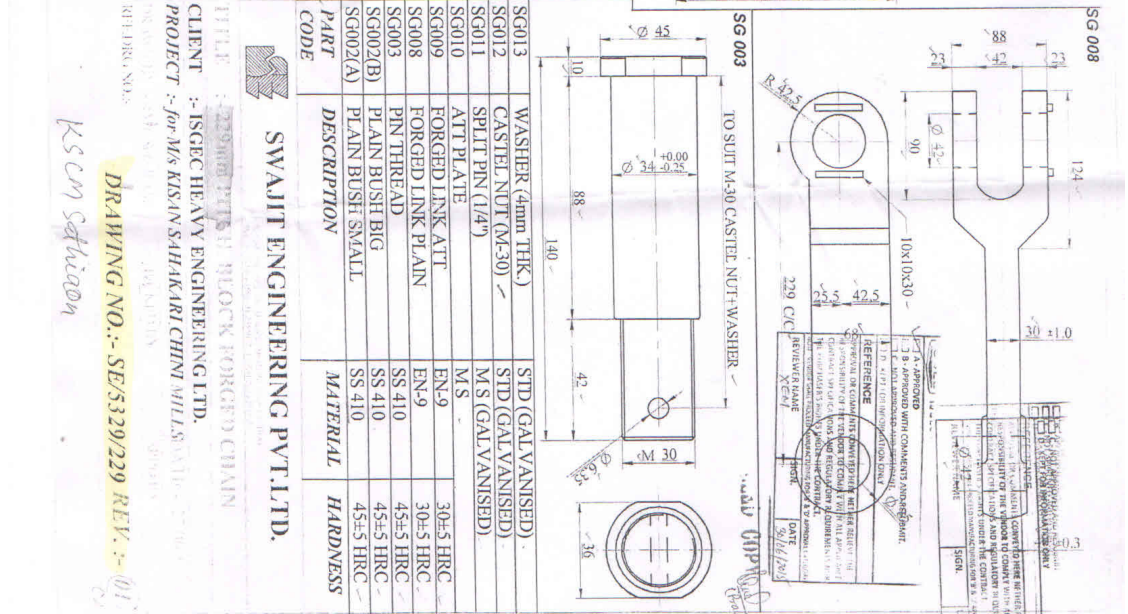
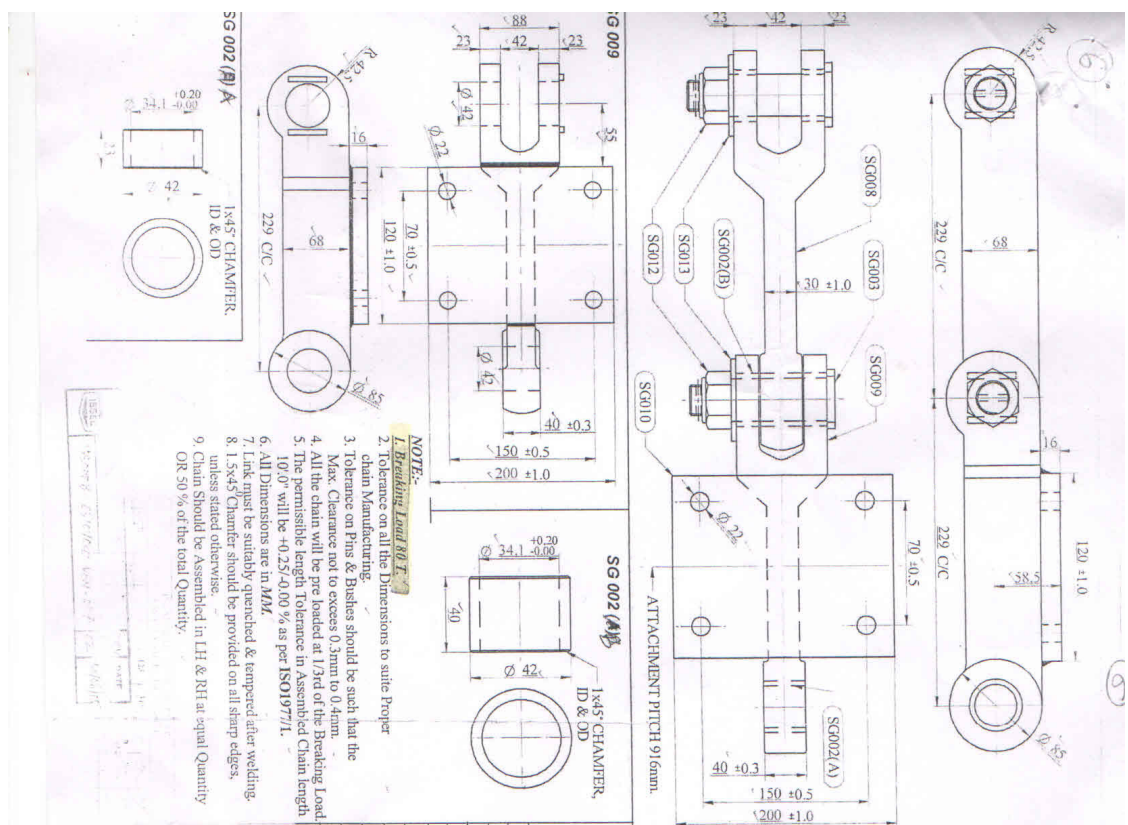

PART CODE	DESCRIPTION	MATERIAL	HARDNESS
SG013	WASHER (4mm THK)	STD (GALVANISED)	
SG012	CASTEL NUT (M-30)	STD (GALVANISED)	
SG011	SPLIT PIN (1/4")	MS (GALVANISED)	
SG010	ATT PLATE	MS	
SG009	FORGED LINK ATT	EN-9	30±5 HRC
SG008	FORGED LINK PLAIN	EN-9	30±5 HRC
SG003	PIN THREAD	SS 410	45±5 HRC
SG002(B)	PLAIN BUSH BIG	SS 410	45±5 HRC
SG002(A)	PLAIN BUSH SMALL	SS 410	45±5 HRC

SWAJIT ENGINEERING PVT.LTD.
 TITLE :- **229mm PITCH HEAVY FORGED CHAIN**
 CLIENT :- **ISGEC HEAVY ENGINEERING LTD.**
 PROJECT :- **for M/S. K/S. INSAHARI CHINI MILL, SAVALI, DIST. RAIPUR, JHARKHAND**
 DRAWING NO. :- **SE/3329/229 REV :- 01**
 KSCM Sathiyam

SECTION III(D) AGREEMENT

ACCEPTANCE OF ORDER WILL BE TREATED AS AGREEMENT EXECUTED

SECTION III(E) : PERFORMANCE STATEMENT

Chain and their spares supplied satisfactorily in previous FIVE year to Cooperative sugar mills/ state sugar corporations / private sugar mills

Name of Company/Firm

Order placed by (Full address of Purchaser)	Order No. & Date	Description & Quantity of ordered goods	Value of order	Date of completion of delivery		Remarks indicating reasons for late delivery, if any
				As per contract	Actual	
1	2	3	4	5	6	7

Signature and seal of the E-Bidder
With name of the authorized person

SECTION III (F) : CAPABILITY STATEMENT (CS)

1. (a) Name and complete mailing address of the business/sales office of the bidder.

(b) Name of Authorized Official

(c) Phone:

(d) Fax:

(e) E-mail:

(f) Principal place of business

(g) Website of Bidder's Firm

2. Parties Will Have To Furnish Under Noted Information During The Technical Discussions With Documentary Proof:

SN	Particulars	Chain and their spares
1	Manufacturing License for Chain and their spares issued by Industries department of State.	
2	Affidavit as per attached proforma for quoting rate in BOQ.	
3	Acceptance of supply of Chain and their spares as per IS Specification given in the technical bid and amended up to date	
4	Detail of Tender Fee	
5	Detail of E.M.D	
6	Orders for supply of Chain and their spares in last five year to sugar mills minimum two order copy of cooperative of any state / Private sector.	
7	Satisfactory performance certificate for supply of Chain and their spares in last five year to sugar mills minimum two performance certificate of any state cooperative / Private sector.	
8	The Bidder/Supplier shall submit the copy of Aadhaar Card of all partner and authorised person if any	
9	Details of last three years turnover duly certified by Chartered Accountant mentions membership and UDIN Number	
10	Copy of last submitted Income Tax Return and PAN card (self attested)	
11	Copy of last audited balance sheet	
12	Details of GST No.	
13	Status of the company along with names of Directors/Partners/Proprietor along with documents.	
14	The bidder/supplier shall submit the copy of Aadhaar Card of all partners and authorized person if any.	
15	Affidavit in relation to the E-tender for debar and integrity (IP) as per attach performa on Rs.100 non judicial Stamp Paper	
16	RTGS details 1. Name of the bank 2. Account number 3. IFSC Code	

Seal and signature of the bidder _____
With Name of Authorized
Official signing the agreement.

TO WHOM IT MAY CONCERN
AFFIDAVIT IN RELATION TO THE E-TENDER FOR DEBAR &
INTEGRITY PACT(IP)

I (Full Name), aged about, S/O Shri (Full Name), is resident of (Permanent address/present address), is the director/representative/partner of M/s (address of registered office), do hereby solemnly affirm and state on oath as under;

1- I/We state and confirm that I/we or our holding company/subsidiary company have not been convicted by any court of law or indicated or adverse orders passed by a Regulatory Authority or Government of India/State Governments/ Undertakings or any FIR related to economic or criminal offence has been lodged against the directors/senior officials of the Company/Firm/me which would cast a doubt on our ability to manage/deal with the public sector unit or which relates to grave offence that outrages the moral sense of the community.

2 -I/We further state and confirm that in regard to matters relating to security and integrity of the country, I/we have not been charge-sheeted/Black-Listed by any agency of the Government of India/State Governments/Undertakings and/or not been convicted for any offence by any court of law by me/us or by any of our holding/subsidiary company.

3. I/We undertake that in case of any change in the facts and circumstances during the agreement period, such change would attract the provisions of disqualification mentioned in tender document.

4. I/We state and confirm that I/we have not been debarred/disqualified from participating in the tender process of Government of India or State Governments or their instrumentalities.

5- I/We state and confirm that the applicant or in case of a Consortium, any member of the Consortium has made, incorrect, misleading or false misrepresentation in the forms, statements and attachments submitted, whether intentionally or unintentionally be dropped from further consideration.

6- Party has been agreed, accepted and undertaken to use, practice and observe all the best, clean, ethical, honest and legal means and behaviour maintaining complete transparency and fairness in all activities concerning Bidding, Contracting/Rate Contracting and performance thereto.

7. Party shall not use any corrupt practices including fraud, misrepresentation, misleading or forged/false documents, concealing/suppressing facts, undue pressures or influences from anyone (written or verbal/telephonic), bribery, rigging, cartelisation, collusion, collusive bidding, cover bidding, Bid suppression and Market allocation

8. The party hereby agrees that he will not indulge in any such activity and will inform Managing Director, UP Cooperative Sugar Factories Federation Ltd/General Manager of relevant Sugar Mill if any such activity is on.

9. In case of failure or default in terms of this affidavit the officers of Federation/Public Authority will be subjected to actions prescribed under the relevant Servant Conduct Rules/Discipline and Appeal Rules etc. including penal actions and prosecution, while the Supplier will bear any or a combination of following penalties:

(a) Cancellation of Contract/Rate Contracts (RCs)

- (b) Cancellation of Registration
- (c) Forfeiture of all securities and performance Bank Guarantees
- (d) Refusal to grant Registration and contracts/RCS for further period of 3 (three) years
- (e) Suspension and/or banning the business dealings for period upto 3 (three) years
- (f) Any other administrative or penal actions as deemed fit.
- (g) Action under IPC/PC Act and other relevant laws of the country.

10. It has been further agreed that the actions as aforesaid except that at 4(g) above will not require any criminal conviction from any court of law or arbitration but will be based on 'No-contest' basis, upon satisfaction of the MD, UPCSFFL, who will be the competent authority to finally decide the matter on strength of such materials/evidence of default/breach of the terms under this IP.

Deponent

Verification

I above named (authorized signatory), do hereby verify the contents of para 1-5 are true to my personal knowledge.

Signed and verified on

Deponent

I identify the deponent who has signed before me.
Advocate

SECTION IV: FINANCIAL e-Bid

IV (A) e –Bid FORM

IV (B) PRICE SCHEDULE/BOQ

SECTION IV(A) : e bid FORM

Date

IFB No. **UPSUGARFED/CHAINSPARES/2024-25/ P-10874**

To: (Name and address of Purchaser)
The Managing Director,
U.P.Cooperative Sugar Factories Federation Ltd,
9-A,Rana Pratap Marg, Lucknow

Dear Sir,

Having examined the e-Bid Documents, we the undersigned, offer to supply.....(Description of Goods and services) in conformity with the said e-Bid Documents for the rates as may be ascertained in accordance with the schedule of rates attached herewith and made part of this e-bid, and hereby undertake that we accept all terms and conditions of E-Tender/contract (section II) of the e-Bid Document and will supply of **Chain and their spares** from our manufacturing works/unit as per the Technical specifications (Section III (c) to your sugar factories. In addition to this, the particulars of our organization such as legal status principal place of business, details of experience and past performance, capability statement and the required e-Bid security in the form of RTGS/ NEFT/ NET BANKING in favour of U.P. Cooperative Sugar Factories Federation Ltd. Lucknow are furnished with this e-Bid form

We further undertake, if our e-Bid is accepted, to deliver the goods in accordance with the delivery schedule specified in the schedule of Requirements(section III(b))

We agree to abide by this e-Bid for the e-Bid validity period specified in Clause 13.1 of the ITB and it shall remain binding upon us and may be accepted at any time before the expiration of that period.

Until a formal contract is prepared and executed, this e-Bid, together with you ,written acceptance thereof and your notification of award shall constitute a binding contract between us.

We undertake that, in competing for (and, if the award is made to us, in executing) the above contract, we will strictly observe the laws against fraud and corruption in force in India namely “ Prevention of Corruption Act 1998”.

We understand that you are not bound to accept the lowest or any e-Bid you may receive.

Datedday of20

.....
(Signature & Name of official)

.....
(In the capacity of)

Duly authorized to sign e-Bid for and on behalf of

SECTION IV(B): PRICE SCHEDULE / BOQ

Vendor Bidding Authority: L.P. 000-operative Sugar Factories Federation & The Customer Name of Work: COMBUSTIBLE - a bidding for supply of CHIPS AND TRIM SPICES FOR VARIOUS COOP SUGAR FACTORIES IN TITAN PROVINCE FOR THE SEASON 2024-25 Contract No: LPSUGAFFED/2024/AM-0024/26-10874									
PRICE SCHEDULE									
ITEM NO.	ITEM DESCRIPTION	UNIT	QUANTITY	ESTIMATED PRICE		TOTAL QUANTITY		TOTAL PRICE	
				UNIT PRICE	TOTAL PRICE	UNIT PRICE	TOTAL PRICE		
1.01
1.02
1.03
1.04
1.05
1.06
1.07
1.08
1.09
1.10
1.11
1.12
1.13
1.14
1.15
1.16
1.17
1.18
1.19
1.20
1.21
1.22
1.23
1.24
1.25
1.26
1.27
1.28
1.29
1.30
1.31
1.32
1.33
1.34
1.35
1.36
1.37
1.38
1.39
1.40
1.41
1.42
1.43
1.44
1.45
1.46
1.47
1.48
1.49
1.50
1.51
1.52
1.53
1.54
1.55
1.56
1.57
1.58
1.59
1.60
1.61
1.62
1.63
1.64
1.65
1.66
1.67
1.68
1.69
1.70
1.71
1.72
1.73
1.74
1.75
1.76
1.77
1.78
1.79
1.80
1.81
1.82
1.83
1.84
1.85
1.86
1.87
1.88
1.89
1.90
1.91
1.92
1.93
1.94
1.95
1.96
1.97
1.98
1.99
2.00